

NOTE 1:
 Can optionally use modified Serial Monitor, which checks PB4 (DTR pin) instead of PP5; In that case, host software must use DTR to activate serial monitor; supports auto-reset feature.

USB2MCU can be attached to J1 and J2.

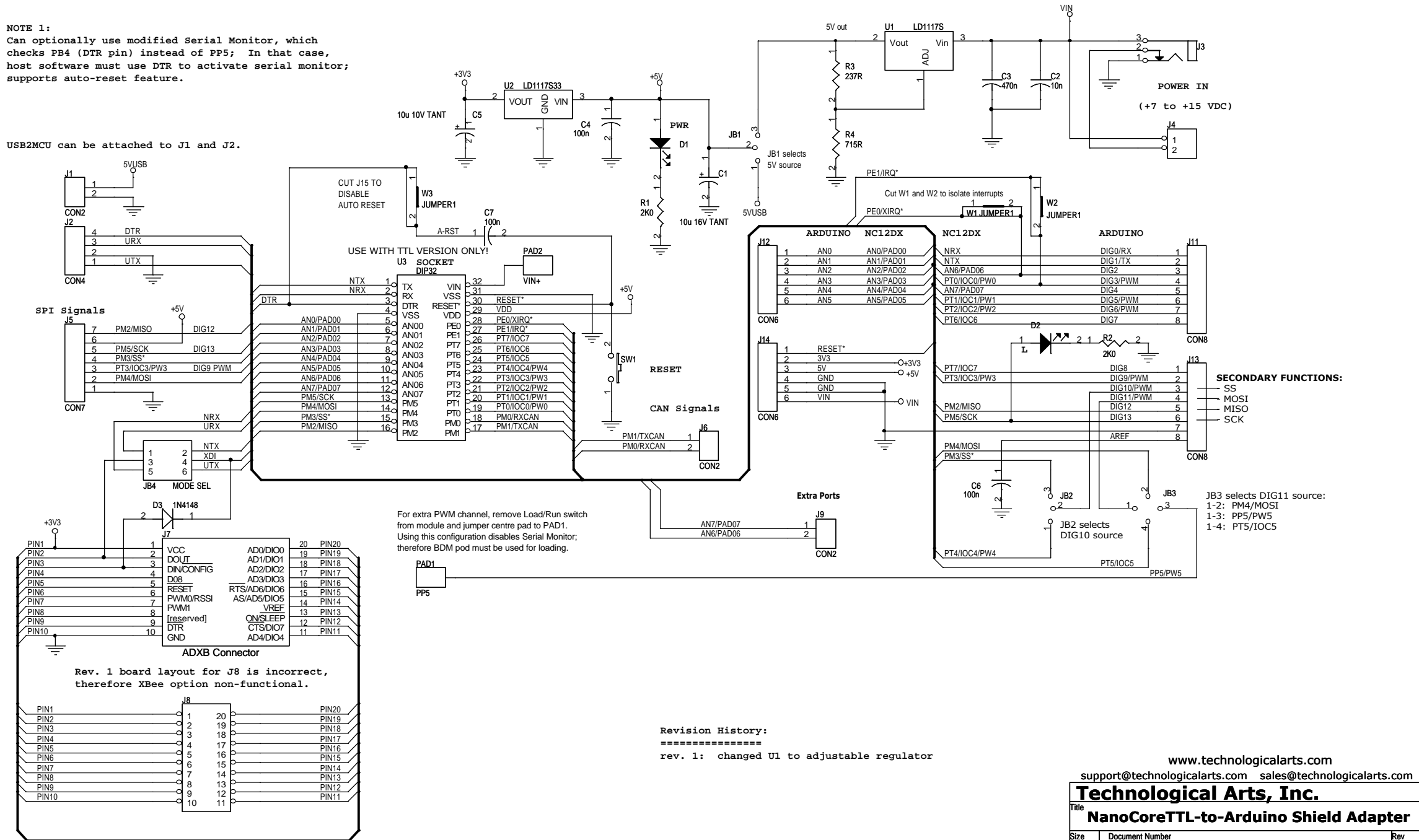

Revision History:
 =====
 rev. 1: changed U1 to adjustable regulator

www.technologicalarts.com
 support@technologicalarts.com sales@technologicalarts.com

Technological Arts, Inc.

Title: **NanoCoreTTL-to-Arduino Shield Adapter**

Size B	Document Number FILE: NCT2ASA0.dsn	Rev 1
--------	------------------------------------	-------

Date: Saturday, May 15, 2010 Sheet 1 of 1