

# SPI

## Block User Guide

### V02.07

**Original Release Date: 21 JAN 2000**

**Revised: 11 Dec 2002**

**Motorola, Inc.**

Motorola reserves the right to make changes without further notice to any products herein to improve reliability, function or design. Motorola does not assume any liability arising out of the application or use of any product or circuit described herein; neither does it convey any license under its patent rights nor the rights of others. Motorola products are not designed, intended, or authorized for use as components in systems intended for surgical implant into the body, or other applications intended to support or sustain life, or for any other application in which the failure of the Motorola product could create a situation where personal injury or death may occur. Should Buyer purchase or use Motorola products for any such unintended or unauthorized application, Buyer shall indemnify and hold Motorola and its officers, employees, subsidiaries, affiliates, and distributors harmless against all claims, costs, damages, and expenses, and reasonable attorney fees arising out of, directly or indirectly, any claim of personal injury or death associated with such unintended or unauthorized use, even if such claim alleges that Motorola was negligent regarding the design or manufacture of the part.

## Revision History

Version Number	Revision Date	Effective Date	Author	Description of Changes
0.1	21 Jan 2000			This spec is based on the Barracuda, with modifications to change the module from 16 bit to 8 bit.
0.2	1 Mar 2000			Template of this document changed as per Version 2.0 SRS.
0.3	14 Jun 2000			<ul style="list-style-type: none"> <li>- Signal names are changed as per the SRS2.0</li> <li>- SPE bit remains set in the Mode Fault error case</li> <li>- Slave SPI does not support div2 and div4 cases</li> </ul>
0.4	31 Aug 2000			<ul style="list-style-type: none"> <li>- Electrical spec added</li> <li>- SPIF flag is cleared by a read access to the status register followed by read access to the data register.</li> </ul>
0.5	13 Mar 2001	13 Mar 2001		- Incorporated feedback regarding format of the document.
0.6	13 Mar 2001	19 Mar 2001		- Incorporated changes as a result of internal discussions and clarification of SRS2
0.7	6 July 2001	6 July 2001		<ul style="list-style-type: none"> <li>- Line is added with respect to SPTEF bit to make spec more clear.</li> <li>- Landscape pages have been removed from pdf.</li> <li>- Extra blank pages have been removed.</li> </ul>
0.8	19 July 2001	19 July 2001		- Line is added with respect to SPE bit to make spec more clear.
V02.02	26 July 2001			<ul style="list-style-type: none"> <li>-Added Document Names</li> <li>-variable definitions and Names have been hidden</li> <li>-Changed chapter 3.9 Errata to Note</li> </ul>
V02.03	28 Sept 2001			- Corrected the status of SPE when MODF is set
V02.04	11 Dec 2001			<ul style="list-style-type: none"> <li>- Added a note for slave operation for MUCts00531</li> <li>- Updated Block Diagram</li> </ul>
V02.05	13 Feb 2002	13 Feb 2002		<ul style="list-style-type: none"> <li>- Cleaned up revision history, summarized three entries with Version Number V2.04 into one</li> <li>- Section 4.6.2 Cleaned up Figures in Table 4-1</li> <li>- Removed note 4.9, because in slave mode baud rates DIV2 and DIV4 are not supported</li> </ul>
V02.06	06 Mar 2002	06 Mar 2002		- Document format update
V02.07	11 Dec 2002	11 Dec 2002		Section 3.3.5 - Added Note

# Table of Contents

## Section 1 Introduction

1.1	Overview . . . . .	9
1.2	Features . . . . .	9
1.3	Modes of Operation . . . . .	9
1.4	Block Diagram . . . . .	10

## Section 2 Signal Description

2.1	Overview . . . . .	11
2.2	Detailed Signal Descriptions . . . . .	11
2.2.1	MOSI . . . . .	11
2.2.2	MISO . . . . .	11
2.2.3	$\overline{SS}$ . . . . .	11
2.2.4	SCK . . . . .	11

## Section 3 Memory Map and Registers

3.1	Overview . . . . .	13
3.2	Module Memory Map . . . . .	13
3.3	Register Descriptions . . . . .	13
3.3.1	SPI Control Register 1 . . . . .	14
3.3.2	SPI Control Register 2 . . . . .	15
3.3.3	SPI Baud Rate Register . . . . .	16
3.3.4	SPI Status Register . . . . .	19
3.3.5	SPI Data Register . . . . .	20

## Section 4 Functional Description

4.1	General . . . . .	21
4.2	Master Mode . . . . .	21
4.3	Slave Mode . . . . .	22
4.4	Transmission Formats . . . . .	23
4.4.1	Clock Phase and Polarity Controls . . . . .	23
4.4.2	CPHA = 0 Transfer Format . . . . .	24
4.4.3	CPHA = 1 Transfer Format . . . . .	25
4.5	SPI Baud Rate Generation . . . . .	27

4.6	Special Features	27
4.6.1	$\overline{SS}$ Output	27
4.6.2	Bidirectional Mode (MOMI or SISO)	28
4.7	Error Conditions	28
4.7.1	Mode Fault Error	29
4.8	Low Power Mode Options	29
4.8.1	SPI in Run Mode	29
4.8.2	SPI in Wait Mode	29
4.8.3	SPI in Stop Mode	30

## Section 5 Reset

5.1	General	31
-----	---------	----

## Section 6 Interrupts

6.1	Interrupt Operation	33
6.1.1	MODF	33
6.1.2	SPIF	33
6.1.3	SPTEF	33

## List of Figures

Figure 1-1	SPI Block Diagram. . . . .	10
Figure 3-2	SPI Control Register 1 (SPICR1). . . . .	14
Figure 3-3	SPI Control Register 2 (SPICR2). . . . .	15
Figure 3-4	SPI Baud Rate Register (SPIBR) . . . . .	16
Figure 3-5	SPI Status Register (SPISR) . . . . .	19
Figure 3-6	SPI Data Register (SPIDR) . . . . .	20
Figure 4-1	Master/Slave Transfer Block Diagram. . . . .	23
Figure 4-2	SPI Clock Format 0 (CPHA = 0) . . . . .	25
Figure 4-3	SPI Clock Format 1 (CPHA = 1) . . . . .	26
Figure 4-4	Baud Rate Divisor Equation. . . . .	27



## List of Tables

Table 3-1	Module Memory Map . . . . .	13
Table 3-2	$\overline{SS}$ Input / Output Selection . . . . .	15
Table 3-3	Bidirectional Pin Configurations . . . . .	16
Table 3-4	SPI Baud Rate Selection . . . . .	17
Table 4-1	Normal Mode and Bidirectional Mode . . . . .	28

Freescale Semiconductor, Inc.





# Section 1 Introduction

## 1.1 Overview

The SPI module allows a duplex, synchronous, serial communication between the MCU and peripheral devices. Software can poll the SPI status flags or the SPI operation can be interrupt driven.

## 1.2 Features

The SPI includes these distinctive features:

- Master mode and slave mode
- Bi-directional mode
- Slave select output
- Mode fault error flag with CPU interrupt capability
- Double-buffered operation
- Serial clock with programmable polarity and phase
- Control of SPI operation during wait mode

## 1.3 Modes of Operation

The SPI functions in three modes, run, wait, and stop.

- Run Mode  
This is the basic mode of operation.
- Wait Mode  
SPI operation in wait mode is a configurable low power mode. Depending on the state of internal bits, the SPI can operate normally when the CPU is in wait mode or the SPI clock generation can be turned off and the SPI module enters a power conservation state during wait mode. During wait mode, any master transmission in progress stops if the SPISWAI bit is set in the SPI control register2. Reception and transmission of a byte as slave continues so that the slave is synchronized to the master.
- Stop Mode  
The SPI is inactive in stop mode for reduced power consumption. The STOP instruction does not affect or depend on SPI register states. Again, reception and transmission of a byte as slave continues to stay synchronized with the master.

This is a high level description only, detailed descriptions of operating modes are contained in section **4.8 Low Power Mode Options**.

## 1.4 Block Diagram

Figure 1-1 is a general block diagram of the SPI.

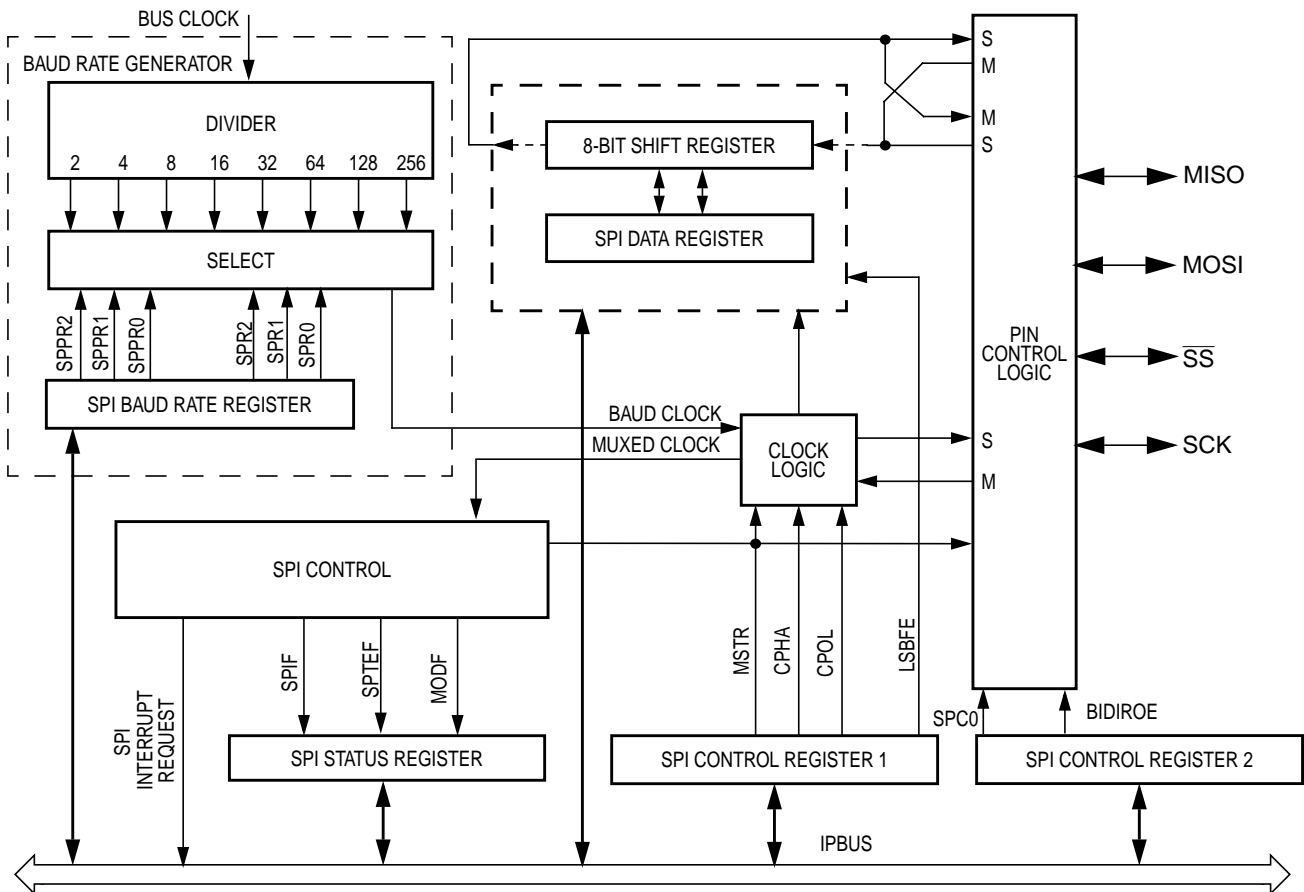

Figure 1-1 SPI Block Diagram

## Section 2 Signal Description

### 2.1 Overview

This section lists the name and description of all ports including inputs and outputs that do, or may, connect off chip. The SPI module has a total of 4 external pins.

### 2.2 Detailed Signal Descriptions

#### 2.2.1 MOSI

This pin is used to transmit data out of the SPI module when it is configured as a Master and receive data when it is configured as slave.

#### 2.2.2 MISO

This pin is used to transmit data out of the SPI module when it is configured as a Slave and receive data when it is configured as Master.

#### 2.2.3 $\overline{SS}$

This pin is used to output the select signal from the SPI module to another peripheral with which a data transfer is to take place.

#### 2.2.4 SCK

This pin is used to output the clock with respect to which the SPI transfers data or receive clock in case of Slave.



## Section 3 Memory Map and Registers

### 3.1 Overview

This section provides a detailed description of all memory and registers accessible to the end user.

### 3.2 Module Memory Map

The memory map for the SPI is given below in **Table 3-1**. The address listed for each register is the sum of a base address and an address offset. The base address is defined at the SoC level and the address offset is defined at the module level. Reads from the reserved bits return zeros and writes to the reserved bits have no effect.

**Table 3-1 Module Memory Map**

Address	Use	Access
\$__0	SPI Control Register 1 (SPICR1)	Read / Write
\$__1	SPI Control Register 2 (SPICR2)	Read / Write <sup>1</sup>
\$__2	SPI Baud Rate Register (SPIBR)	Read / Write <sup>1</sup>
\$__3	SPI Status Register (SPISR)	Read <sup>2</sup>
\$__4	Reserved	__ 2 3
\$__5	SPI Data Register (SPIDR)	Read / Write
\$__6	Reserved	__ 2 3
\$__7	Reserved	__ 2 3

NOTES:

1. Certain bits are non-writable.
2. Writes to this register are ignored.
3. Reading from this register returns all zeros.

### 3.3 Register Descriptions

This section consists of register descriptions in address order. Each description includes a standard register diagram with an associated figure number. Details of register bit and field function follow the register diagrams, in bit order.

### 3.3.1 SPI Control Register 1

Register Address: \$\_\_0

	Bit 7	6	5	4	3	2	1	Bit 0
R	SPIE	SPE	SPTIE	MSTR	CPOL	CPHA	SSOE	LSBFE
W								
Reset:	0	0	0	0	0	1	0	0

**Figure 3-2 SPI Control Register 1 (SPICR1)**

Read: anytime

Write: anytime

**SPIE** — SPI Interrupt Enable Bit

This bit enables SPI interrupts each time the SPIF or MODF status flag is set.

- 1 = SPI interrupts enabled.
- 0 = SPI interrupts disabled.

**SPE** — SPI System Enable Bit

This bit enables the SPI system and dedicates the SPI port pins to SPI system functions.

- 1 = SPI port pins are dedicated to SPI functions.
- 0 = SPI disabled (lower power consumption).

**SPTIE** — SPI Transmit Interrupt Enable

This bit enables SPI interrupt generated each time the SPTEF flag is set.

- 1 = SPTEF interrupt enabled.
- 0 = SPTEF interrupt disabled.

**MSTR** — SPI Master/Slave Mode Select Bit

- 1 = Master mode
- 0 = Slave mode

**CPOL** — SPI Clock Polarity Bit

This bit selects an inverted or non-inverted SPI clock. To transmit data between SPI modules, the SPI modules must have identical CPOL values.

- 1 = Active-low clocks selected; SCK idles high
- 0 = Active-high clocks selected; SCK idles low

**CPHA** — SPI Clock Phase Bit

This bit is used to shift the SCK serial clock.

- 1 = The first SCK edge is issued at the beginning of the 8-cycle transfer operation
- 0 = The first SCK edge is issued one-half cycle into the 8-cycle transfer operation

SSOE — Slave Select Output Enable

The  $\overline{SS}$  output feature is enabled only in the master mode by asserting the SSOE as shown in **Table 3-2**.

**Table 3-2  $\overline{SS}$  Input / Output Selection**

MOD FEN	SSOE	Master Mode	Slave Mode
0	0	$\overline{SS}$ not used by SPI	$\overline{SS}$ input
0	1	$\overline{SS}$ not used by SPI	$\overline{SS}$ input
1	0	$\overline{SS}$ input with MODF feature	$\overline{SS}$ input
1	1	$\overline{SS}$ output	$\overline{SS}$ input

LSBFE — SPI LSB-First Enable

This bit does not affect the position of the msb and lsb in the data register. Reads and writes of the data register always have the msb in bit 7.

- 1 = Data is transferred least significant bit first.
- 0 = Data is transferred most significant bit first.

### 3.3.2 SPI Control Register 2

Register Address: \$\_\_1

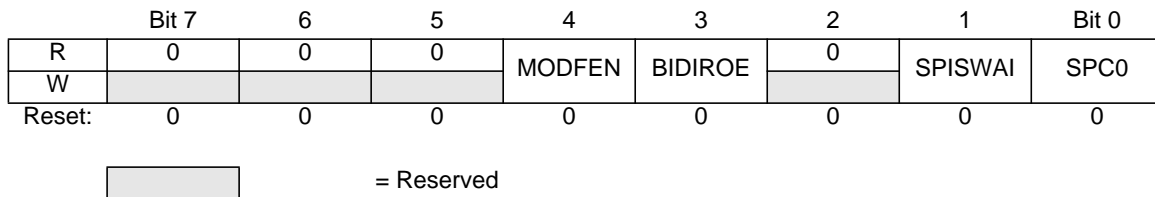

**Figure 3-3 SPI Control Register 2 (SPICR2)**

Read: anytime

Write: anytime; writes to the reserved bits have no effect

MODFEN — Mode Fault Enable Bit

This bit when set allows the MODF flag to be set. If the MODF flag is set, clearing the MODFEN does not clear the MODF flag. If the SPI is enabled as master and the MODFEN bit is low, then the  $\overline{SS}$  pin is not used by the SPI.

When the SPI is enabled as a slave, the  $\overline{SS}$  is available only as an input regardless of the value of MODFEN.

- 1 = Enable setting the MODF error
- 0 = Disable the MODF error

**BIDIROE** — Output enable in the Bidirectional mode of operation

This bit along with the MSTR bit of SPCR1 is used to enable the output buffer when the SPI is configured in bidirectional mode.

- 1 = Output buffer enabled
- 0 = Output buffer disabled

**SPISWAI** — SPI Stop in Wait Mode Bit

This bit is used for power conservation while in wait mode.

- 1 = Stop SPI clock generation when in wait mode
- 0 = SPI clock operates normally in wait mode

**SPC0** — Serial Pin Control Bit 0

With the MSTR control bit, this bit enables bidirectional pin configurations as shown in **Table 3-3**.

**Table 3-3 Bidirectional Pin Configurations**

Pin Mode	SPC0	MSTR	MISO <sup>1</sup>	MOSI <sup>2</sup>	SCK <sup>3</sup>	$\overline{SS}$ <sup>4</sup>
A	0	0	Slave Out	Slave In	SCK in	$\overline{SS}$ in
B		1	Master In	Master Out	SCK out	$\overline{SS}$ I/O
C	1	0	Slave I/O	—	SCK in	$\overline{SS}$ In
D		1	—	Master I/O	SCK out	$\overline{SS}$ I/O

NOTES:

1. Slave output is enabled if BIDIROE bit = 1,  $\overline{SS}$  = 0, and MSTR = 0 (C)
2. Master output is enabled if BIDIROE bit = 1 and MSTR = 1 (D)
3. SCK output is enabled if MSTR = 1 (B, D)
4.  $\overline{SS}$  output is enabled if MODFEN bit = 1, SSOE = 1, and MSTR = 1 (B, D).

### 3.3.3 SPI Baud Rate Register

Register Address: \$\_\_2

	Bit 7	6	5	4	3	2	1	Bit 0
R	0	SPPR2	SPPR1	SPPR0	0	SPR2	SPR1	SPR0
W								
Reset:	0	0	0	0	0	0	0	0

 = Reserved

**Figure 3-4 SPI Baud Rate Register (SPIBR)**

Read: anytime

Write: anytime; writes to the reserved bits have no effect

**NOTE:** Writing to this register during data transfers may cause spurious results.



SPPR2–SPPR0 — SPI Baud Rate Preselection Bits

SPR2–SPR0 — SPI Baud Rate Selection Bits

These bits specify the SPI baud rates as shown in the table below

The baud rate divisor equation is as follows

$$\text{BaudRateDivisor} = (\text{SPPR} + 1) \cdot 2^{(\text{SPR} + 1)}$$

$$\text{Baud Rate} = \text{Bus clock} / \text{BaudRateDivisor}$$

**Table 3-4 SPI Baud Rate Selection**

SPPR2	SPPR1	SPPR0	SPR2	SPR1	SPR0	SPI Module Clock Divisor
0	0	0	0	0	0	2
0	0	0	0	0	1	4
0	0	0	0	1	0	8
0	0	0	0	1	1	16
0	0	0	1	0	0	32
0	0	0	1	0	1	64
0	0	0	1	1	0	128
0	0	0	1	1	1	256
0	0	1	0	0	0	4
0	0	1	0	0	1	8
0	0	1	0	1	0	16
0	0	1	0	1	1	32
0	0	1	1	0	0	64
0	0	1	1	0	1	128
0	0	1	1	1	0	256
0	0	1	1	1	1	512
0	1	0	0	0	0	6
0	1	0	0	0	1	12
0	1	0	0	1	0	24
0	1	0	0	1	1	48
0	1	0	1	0	0	96
0	1	0	1	0	1	192
0	1	0	1	1	0	384
0	1	0	1	1	1	768
0	1	1	0	0	0	8
0	1	1	0	0	1	16
0	1	1	0	1	0	32
0	1	1	0	1	1	64
0	1	1	1	0	0	128
0	1	1	1	0	1	256

Table 3-4 SPI Baud Rate Selection

SPPR2	SPPR1	SPPR0	SPR2	SPR1	SPR0	SPI Module Clock Divisor
0	1	1	1	1	0	512
0	1	1	1	1	1	1024
1	0	0	0	0	0	10
1	0	0	0	0	1	20
1	0	0	0	1	0	40
1	0	0	0	1	1	80
1	0	0	1	0	0	160
1	0	0	1	0	1	320
1	0	0	1	1	0	640
1	0	0	1	1	1	1280
1	0	1	0	0	0	12
1	0	1	0	0	1	24
1	0	1	0	1	0	48
1	0	1	0	1	1	96
1	0	1	1	0	0	192
1	0	1	1	0	1	384
1	0	1	1	1	0	768
1	0	1	1	1	1	1536
1	1	0	0	0	0	14
1	1	0	0	0	1	28
1	1	0	0	1	0	56
1	1	0	0	1	1	112
1	1	0	1	0	0	224
1	1	0	1	0	1	448
1	1	0	1	1	0	896
1	1	0	1	1	1	1792
1	1	1	0	0	0	16
1	1	1	0	0	1	32
1	1	1	0	1	0	64
1	1	1	0	1	1	128
1	1	1	1	0	0	256
1	1	1	1	0	1	512
1	1	1	1	1	0	1024
1	1	1	1	1	1	2048

**NOTE:** *DIV2 and DIV4 are not supported in slave mode of SPI.*

### 3.3.4 SPI Status Register

Register Address: \$\_\_3

	Bit 7	6	5	4	3	2	1	Bit 0
R	SPIF	0	SPTEF	MODF	0	0	0	0
W								
Reset:	0	0	1	0	0	0	0	0

= Reserved

**Figure 3-5 SPI Status Register (SPISR)**

Read: anytime

Write: has no effect

#### SPIF — SPIF Interrupt Flag

This bit is set after the eighth SCK cycle in a data transfer and is cleared by reading the SPISR register (with SPIF set) followed by a read access to the SPI data register.

- 1 = New data Copied to SPIDR
- 0 = Transfer not yet complete

#### SPTEF — SPI Transmit Empty Interrupt Flag

This bit is set when there is room in the transmit data buffer. It is cleared by reading SPISR with SPTEF set, followed by writing a data value to the transmit buffer at SPIDR. SPISR must be read with SPTEF=1 before writing data to SPIDR or the SPIDR write will be ignored. SPTEF generates an SPTEF CPU interrupt request if the SPTIE bit in the SPICR1 is also set. SPTEF is automatically set when a data byte transfers from the transmit buffer into the transmit shift register. For an idle SPI (no data in the transmit buffer or the shift register and no transfer in progress), data written to SPIDR is transferred to the shifter almost immediately so SPTEF is set within two bus cycles allowing a second 8-bit data value to be queued into the transmit buffer. After completion of the transfer of the value in the shift register, the queued value from the transmit buffer will automatically move to the shifter and SPTEF will be set to indicate there is room for new data in the transmit buffer. If no new data is waiting in the transmit buffer, SPTEF simply remains set and no data moves from the buffer to the shifter.

- 1 = SPI Data register empty
- 0 = SPI Data register not empty

**NOTE:** Do not write to the SPI data register unless the SPTEF bit is high. Any such write to the SPI Data Register before reading SPTEF=1 is effectively ignored

#### MODF — Mode Fault Flag

This bit is set if the  $\overline{SS}$  input becomes low while the SPI is configured as a master. The flag is cleared automatically by a read of the SPI status register (with MODF set) followed by a write to the SPI control register 1. The MODF flag is set only if the MODFEN bit of SPICR2 register is set. Refer to MODFEN bit description in **3.3.2 SPI Control Register 2**.

- 1 = Mode fault has occurred.
- 0 = Mode fault has not occurred.

### 3.3.5 SPI Data Register

Register Address: \$\_\_5

	Bit 7	6	5	4	3	2	1	Bit 0
R	Bit 7	6	5	4	3	2	2	Bit 0
W								
Reset:	0	0	0	0	0	0	0	0

**Figure 3-6 SPI Data Register (SPIDR)**

Read: anytime; normally read only after SPIF is set

Write: anytime; see SPTEF

The SPI Data register is both the input and output register for SPI data. A write to this register allows a data byte to be queued and transmitted. For a SPI configured as a master, a queued data byte is transmitted immediately after the previous transmission has completed. The SPI Transmitter empty flag in SPISR indicates when the SPI data register is ready to accept new data.

**NOTE:** *Do not write to the SPI data register unless the SPTEF bit is high.*

Reading the data can occur anytime from after the SPIF is set to before the end of the next transfer. If the SPIF is not serviced by the end of the successive transfers, those data bytes are lost and the data within the SPIDR retains the first byte until SPIF is serviced.

**NOTE:** *After reset the content of the SPI Shift Register is undefined until a data byte is stored into SPIDR.*

## Section 4 Functional Description

### 4.1 General

The SPI module allows a duplex, synchronous, serial communication between the MCU and peripheral devices. Software can poll the SPI status flags or SPI operation can be interrupt driven.

The SPI system is enabled by setting the SPI enable (SPE) bit in SPI control register 1. While SPE is set, the four associated SPI port pins are dedicated to the SPI function as:

- Slave select ( $\overline{SS}$ )
- Serial clock (SCK)
- Master out/slave in (MOSI)
- Master in/slave out (MISO)

The main element of the SPI system is the SPI data register. The 8-bit data register in the master and the 8-bit data register in the slave are linked by the MOSI and MISO pins to form a distributed 16-bit register. When a data transfer operation is performed, this 16-bit register is serially shifted eight bit positions by the SCK clock from the master; data is exchanged between the master and the slave. Data written to the master SPI data register becomes the output data for the slave, and data read from the master SPI data register after a transfer operation is the input data from the slave.

A write to the SPI data register puts data into the transmit buffer if the previous transmission was complete. When a transfer is complete, received data is moved into a receive data register. Data may be read from this double-buffered system any time before the next transfer is complete. This 8-bit data register acts as the SPI receive data register for reads and as the SPI transmit data register for writes. A single SPI register address is used for reading data from the read data buffer and for writing data to the shifter.

The clock phase control bit (CPHA) and a clock polarity control bit (CPOL) in the SPI control register 1 select one of four possible clock formats to be used by the SPI system. The CPOL bit simply selects a non-inverted or inverted clock. The CPHA bit is used to accommodate two fundamentally different protocols by shifting the clock by a half cycle or by not shifting the clock (see **4.4 Transmission Formats**).

The SPI can be configured to operate as a master or as a slave. When MSTR in SPI control register 1 is set, the master mode is selected; when the MSTR bit is clear, the slave mode is selected.

### 4.2 Master Mode

The SPI operates in master mode when the MSTR bit is set. Only a master SPI module can initiate transmissions. A transmission begins by writing to the master SPI data register. If the shift register is empty, the byte immediately transfers to the shift register. The byte begins shifting out on the MOSI pin under the control of the serial clock.

The SPR2, SPR1, and SPR0 baud rate selection bits in conjunction with the SPPR2, SPPR1, and SPPR0 baud rate preselection bits in the SPI baud rate register control the baud rate generator and determine the

speed of the shift register. The SCK pin is the SPI clock output. Through the SCK pin, the baud rate generator of the master controls the shift register of the slave peripheral.

In master mode, the function of the serial data output pin (MOSI) and the serial data input pin (MISO) is determined by the SPC0 and MSTR control bits.

The  $\overline{SS}$  pin is normally an input which should remain in the inactive high state. However, in the master mode, if both MODFEN bit and SSOE bit are set, then the  $\overline{SS}$  pin is the slave select output.

The  $\overline{SS}$  output becomes low during each transmission and is high when the SPI is in the idling state. If the  $\overline{SS}$  input becomes low while the SPI is configured as a master, it indicates a mode fault error where more than one master may be trying to drive the MOSI and SCK lines simultaneously. In this case, the SPI immediately clears the output buffer enables associated with the MISO, MOSI (or MOMI), and SCK pins so that these pins become inputs. This mode fault error also clears the MSTR control bit and sets the mode fault (MODF) flag in the SPI status register. If the SPI interrupt enable bit (SPIE) is set when the MODF bit gets set, then an SPI interrupt sequence is also requested

When a write to the SPI data register in the master occurs, there is a half SCK-cycle delay. After the delay, SCK is started within the master. The rest of the transfer operation differs slightly, depending on the clock format specified by the SPI clock phase bit, CPHA, in SPI control register 1 (see **4.4 Transmission Formats**).

### 4.3 Slave Mode

The SPI operates in slave mode when the MSTR bit in SPI control register 1 is clear. In slave mode, SCK is the SPI clock input from the master, and  $\overline{SS}$  is the slave select input. Before a data transmission occurs, the  $\overline{SS}$  pin of the slave SPI must be at logic 0.  $\overline{SS}$  must remain low until the transmission is complete.

In slave mode, the function of the serial data output pin (MISO) and serial data input pin (MOSI) is determined by the SPC0 bit in SPI control register 2 and the MSTR control bit. While in slave mode, the  $\overline{SS}$  input controls the serial data output pin; if  $\overline{SS}$  is high (not selected), the serial data output pin is high impedance, and, if  $\overline{SS}$  is low the first bit in the SPI data register is driven out of the serial data output pin. Also, if the slave is not selected ( $\overline{SS}$  is high), then the SCK input is ignored and no internal shifting of the SPI shift register takes place.

Although the SPI is capable of duplex operation, some SPI peripherals are capable of only receiving SPI data in a slave mode. For these simpler devices, there is no serial data out pin.

**NOTE:** *When peripherals with duplex capability are used, take care not to simultaneously enable two receivers whose serial outputs drive the same system slave's serial data output line.*

As long as no more than one slave device drives the system slave's serial data output line, it is possible for several slaves to receive the same transmission from a master, although the master would not receive return information from all of the receiving slaves.

If the CPHA bit in SPI control register 1 is clear, odd numbered edges on the SCK input cause the data at the serial data input pin to be latched. Even numbered edges cause the value previously latched from the serial data input pin to shift into the LSB of the SPI shifter.

If the CPHA bit is set, even numbered edges on the SCK input cause the data at the serial data input pin to be latched. Odd numbered edges cause the value previously latched from the serial data input pin to shift into the LSB of the SPI shifter.

**NOTE:** *In slave mode, the control bits CPHA and CPOL of the SPI should be configured only when SPI is disabled else it may lead to incorrect data transfer. Care must be taken to avoid driver collisions in SPI disabled state, because SPI port pins are then not under the control of the SPI. For recommended actions refer to the Device User Guide, SPI section.*

When CPHA is set, the first edge is used to get the first data bit onto the serial data output pin. When CPHA is clear and the  $\overline{SS}$  input is low (slave selected), the first bit of the SPI data is driven out of the serial data output pin. After the eighth shift, the transfer is considered complete and the received data is transferred into the SPI data register. To indicate transfer is complete, the SPIF flag in the SPI status register is set.

## 4.4 Transmission Formats

During an SPI transmission, data is transmitted (shifted out serially) and received (shifted in serially) simultaneously. The serial clock (SCK) synchronizes shifting and sampling of the information on the two serial data lines. A slave select line allows selection of an individual slave SPI device; slave devices that are not selected do not interfere with SPI bus activities. Optionally, on a master SPI device, the slave select line can be used to indicate multiple-master bus contention.

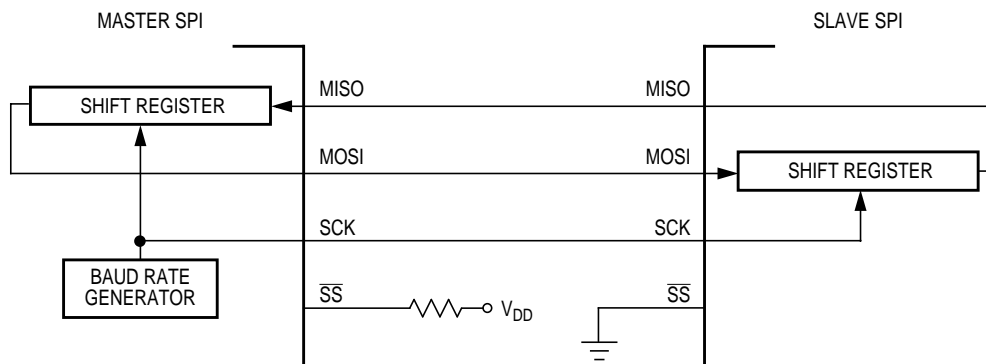

Figure 4-1 Master/Slave Transfer Block Diagram

### 4.4.1 Clock Phase and Polarity Controls

Using two bits in the SPI control register1, software selects one of four combinations of serial clock phase and polarity.

The CPOL clock polarity control bit specifies an active high or low clock and has no significant effect on the transmission format.

The CPHA clock phase control bit selects one of two fundamentally different transmission formats.

Clock phase and polarity should be identical for the master SPI device and the communicating slave device. In some cases, the phase and polarity are changed between transmissions to allow a master device to communicate with peripheral slaves having different requirements.

**NOTE:** *It is recommended that software writes to the SPI control register to change CPHA, CPOL or MSTR bits only in the idle state of the SPI. If these bits are changed during the transmission, data transmission gets corrupted.*

#### 4.4.2 CPHA = 0 Transfer Format

The first edge on the SCK line is used to clock the first data bit of slave into the master and the first data bit of master into the slave. In some peripherals, the first bit of the slave's data is available at the slave data out pin as soon as the slave is selected. In this format, the first SCK edge is not issued until a half cycle into the 8-cycle transfer operation. The first edge of SCK is delayed a half cycle by clearing the CPHA bit.

The SCK output from the master remains in the inactive state for a half SCK period before the first edge appears. A half SCK cycle later, the second edge appears on the SCK line. When this second edge occurs, the value previously latched from the serial data input pin is shifted into the LSB of the shifter.

After this second edge, the next bit of the SPI master data is transmitted out of the serial data output pin of the master to the serial input pin on the slave. This process continues for a total of 16 edges on the SCK line, with data being latched on odd numbered edges and shifted on even numbered edges.

Data reception is double buffered. Data is shifted serially into the SPI shift register during the transfer and is transferred to the parallel SPI data register after the last bit is shifted in.

After the 16th (last) SCK edge:

- Data that was previously in the master SPI data register should now be in the slave data register and the data that was in the slave data register should be in the master.
- The SPIF flag in the SPI status register is set indicating that the transfer is complete.

**Figure 4-2** is a timing diagram of an SPI transfer where CPHA = 0. SCK waveforms are shown for CPOL = 0 and CPOL = 1. The diagram may be interpreted as a master or slave timing diagram since the SCK, MISO, and MOSI pins are connected directly between the master and the slave. The MISO signal is the output from the slave and the MOSI signal is the output from the master. The  $\overline{SS}$  pin of the master must be either high or reconfigured as a general-purpose output not affecting the SPI.



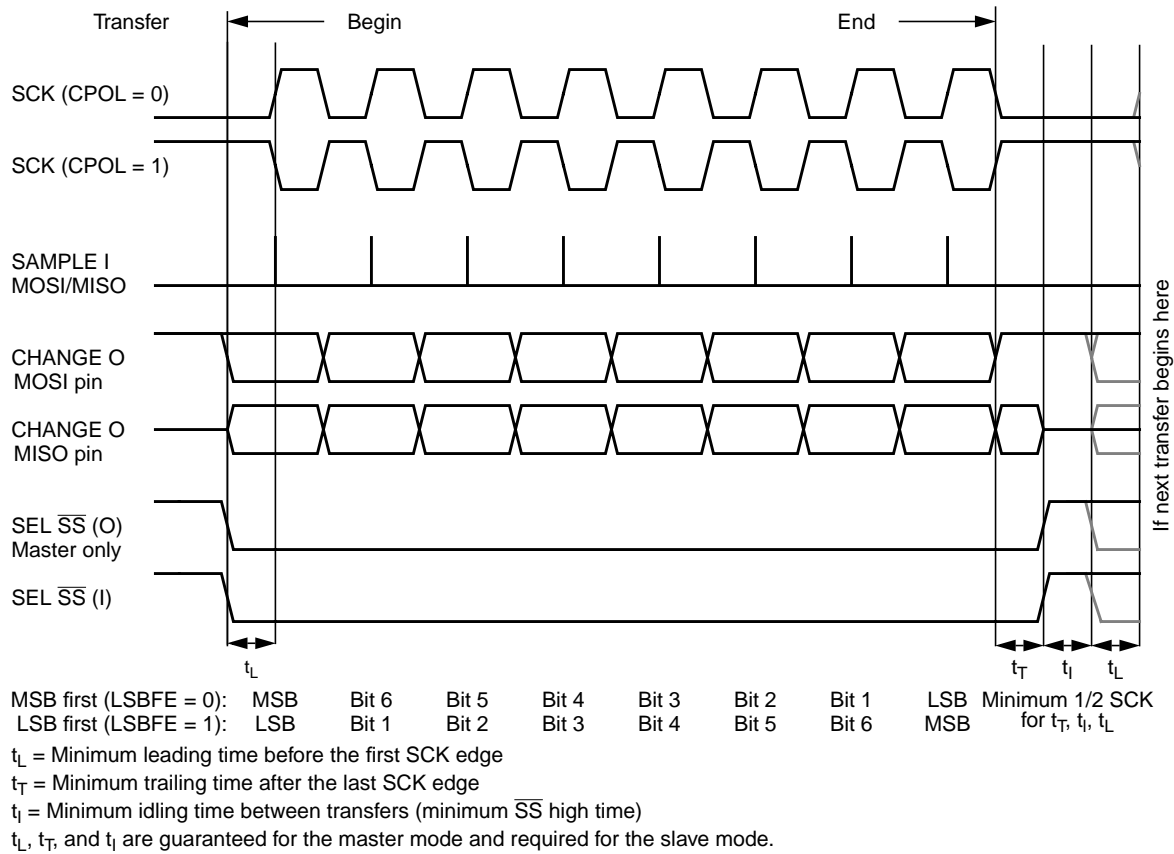

Figure 4-2 SPI Clock Format 0 (CPHA = 0)

The  $\overline{SS}$  line should be deasserted at least for minimum idle time (half SCK cycle) between the successive transfers ( $\overline{SS}$  should not be tied low all the times in this mode). If  $\overline{SS}$  is not deasserted between the successive transmission then the new byte written to the data register would not be transmitted, instead the last received byte would be transmitted.

#### 4.4.3 CPHA = 1 Transfer Format

Some peripherals require the first SCK edge before the first data bit becomes available at the data out pin; the second edge clocks data into the system. In this format, the first SCK edge is issued by setting the CPHA bit at the beginning of the 8-cycle transfer operation.

The first edge of SCK occurs immediately after the half SCK clock cycle synchronization delay. This first edge commands the slave to transfer its most significant data bit to the serial data input pin of the master.

A half SCK cycle later, the second edge appears on the SCK pin. This is the latching edge for both the master and slave.

When the third edge occurs, the value previously latched from the serial data input pin is shifted into the LSB of the SPI shifter. After this edge, the next bit of the master data is coupled out of the serial data output pin of the master to the serial input pins on the slave.

This process continues for a total of 16 edges on the SCK line with data being latched on even numbered edges and shifting taking place on odd numbered edges.

Data reception is double buffered; data is serially shifted into the SPI shift register during the transfer and is transferred to the parallel SPI data register after the last bit is shifted in.

After the 16th SCK edge:

- Data that was previously in the SPI data register of the master is now in the data register of the slave, and data that was in the data register of the slave is in the master.
- The SPIF flag bit in SPISR is set indicating that the transfer is complete.

**Figure 4-3** shows two clocking variations for CPHA = 1. The diagram may be interpreted as a master or slave timing diagram since the SCK, MISO, and MOSI pins are connected directly between the master and the slave. The MISO signal is the output from the slave, and the MOSI signal is the output from the master. The  $\overline{SS}$  line is the slave select input to the slave. The  $\overline{SS}$  pin of the master must be either high or reconfigured as a general-purpose output not affecting the SPI.

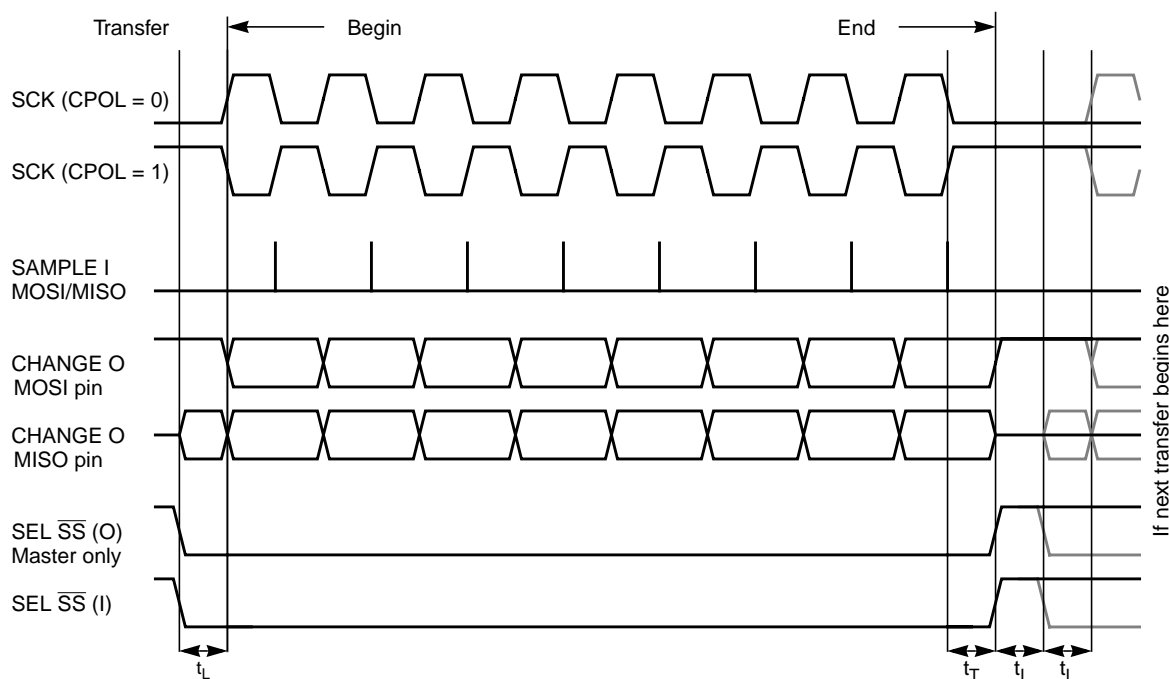

MSB first (LSBFE = 0): MSB Bit 6 Bit 5 Bit 4 Bit 3 Bit 2 Bit 1 LSB Minimum 1/2 SCK  
 LSB first (LSBFE = 1): LSB Bit 1 Bit 2 Bit 3 Bit 4 Bit 5 Bit 6 MSB for  $t_T$ ,  $t_I$ ,  $t_L$

$t_L$  = Minimum leading time before the first SCK edge  
 $t_T$  = Minimum trailing time after the last SCK edge  
 $t_I$  = Minimum idling time between transfers (minimum  $\overline{SS}$  high time)  
 $t_L$ ,  $t_T$ , and  $t_I$  are guaranteed for the master mode and required for the slave mode.

**Figure 4-3 SPI Clock Format 1 (CPHA = 1)**

The  $\overline{SS}$  line can remain active low between successive transfers (can be tied low at all times). This format is sometimes preferred in systems having a single fixed master and a single slave that drive the MISO data line.

The SPI interrupt request flag (SPIF) is common to both the master and slave modes. SPIF gets set after the last SCK edge in a data transfer operation to indicate that the transfer is complete though transfer is actually complete half SCK cycle later.

## 4.5 SPI Baud Rate Generation

Baud rate generation consists of a series of divider stages. Six bits in the SPI baud rate register (SPPR2, SPPR1, SPPR0, SPR2, SPR1, and SPR0) determine the divisor to the SPI module clock which results in the SPI baud rate.

The SPI clock rate is determined by the product of the value in the baud rate preselection bits (SPPR2–SPPR0) and the value in the baud rate selection bits (SPR2–SPR0). The module clock divisor equation is shown in **Figure 4-4**.

When all bits are clear (the default condition), the SPI module clock is divided by 2. When the selection bits (SPR2–SPR0) are 001 and the preselection bits (SPPR2–SPPR0) are 000, the module clock divisor becomes 4. When the selection bits are 010, the module clock divisor becomes 8 etc.

When the preselection bits are 001, the divisor determined by the selection bits is multiplied by 2. When the preselection bits are 010, the divisor is multiplied by 3, etc. The two sets of selects allows the clock to be divided by a non-power of two to achieve other baud rates such as divide by 6, divide by 10, etc.

The baud rate generator is activated only when the SPI is in the master mode and a serial transfer is taking place. In the other cases, the divider is disabled to decrease  $I_{DD}$  current.

$$\text{BaudRateDivisor} = (\text{SPPR} + 1) \cdot 2^{(\text{SPR} + 1)}$$

**Figure 4-4 Baud Rate Divisor Equation**

## 4.6 Special Features

### 4.6.1 $\overline{SS}$ Output

The  $\overline{SS}$  output feature automatically drives the  $\overline{SS}$  pin low during transmission to select external devices and drives it high during idle to deselect external devices. When  $\overline{SS}$  output is selected, the  $\overline{SS}$  output pin is connected to the  $\overline{SS}$  input pin of the external device.

The  $\overline{SS}$  output is available only in master mode during normal SPI operation by asserting SSOE and MODFEN bit as shown in **Table 3-2**.

The mode fault feature is disabled while  $\overline{SS}$  output is enabled.

**NOTE:** Care must be taken when using the  $\overline{SS}$  output feature in a multimaster system since the mode fault feature is not available for detecting system errors between masters.

### 4.6.2 Bidirectional Mode (MOMI or SISO)

The bidirectional mode is selected when the SPC0 bit is set in SPI control register 2 (see **Table 4-1 Normal Mode and Bidirectional Mode**). In this mode, the SPI uses only one serial data pin for the interface with external device(s). The MSTR bit decides which pin to use. The MOSI pin becomes the serial data I/O (MOMI) pin for the master mode, and the MISO pin becomes serial data I/O (SISO) pin for the slave mode. The MISO pin in the master mode and MOSI pin in the slave mode are not used by the SPI in Bidirectional Mode.

**Table 4-1 Normal Mode and Bidirectional Mode**

When SPE = 1	Master Mode MSTR = 1	Slave Mode MSTR = 0
<b>Normal Mode</b> SPC0 = 0		
<b>Bidirectional Mode</b> SPC0 = 1		

The direction of each serial I/O pin depends on the BIDIROE bit. If the pin is configured as an output, serial data from the shift register is driven out on the pin. The same pin is also the serial input to the shift register.

The SCK is output for the master mode and input for the slave mode.

The  $\overline{SS}$  is the input or output for the master mode, and it is always the input for the slave mode.

The bidirectional mode does not affect SCK and  $\overline{SS}$  functions.

## 4.7 Error Conditions

The SPI has one error condition:

- Mode fault error

### 4.7.1 Mode Fault Error

If the  $\overline{SS}$  input becomes low while the SPI is configured as a master, it indicates a system error where more than one master may be trying to drive the MOSI and SCK lines simultaneously. This condition is not permitted in normal operation; the MODF bit in the SPI status register is set automatically provided the MODFEN bit is set.

In the special case where the MODFEN bit is cleared, the  $\overline{SS}$  pin is a general purpose input/output pin for the SPI system configured in master mode. In this special case, the mode error function is inhibited and MODF remains cleared. In case the SPI system is configured as a slave, the  $\overline{SS}$  pin is a dedicated input pin. Mode fault error doesn't occur in slave mode.

When a mode fault error occurs, the MSTR bit in control register SPICR1 is cleared, MODF bit in the status register is set and the output enable for the SCK, MISO and MOSI pins are de-asserted. So SCK, MISO and MOSI pins are forced to be high impedance inputs to avoid any possibility of conflict with another output driver.

If the mode fault error occurs in the bidirectional mode for a SPI system configured in master mode, output enable of the MOMI (MOSI in bidirectional mode) is cleared if it was set but MISO (SISO) is not affected. No mode fault error occurs in the bidirectional mode for SPI system configured in slave mode.

The mode fault flag is cleared automatically by a read of the SPI status register (with MODF set) followed by a write to SPI control register 1.

## 4.8 Low Power Mode Options

### 4.8.1 SPI in Run Mode

In run mode with the SPI system enable (SPE) bit in the SPI control register clear, the SPI system is in a low-power, disabled state. SPI registers can still be accessed, but clocks to the core of this module are disabled.

### 4.8.2 SPI in Wait Mode

SPI operation in wait mode depends upon the state of the SPISWAI bit in SPI control register 2.

- If SPISWAI is clear, the SPI operates normally when the CPU is in wait mode
- If SPISWAI is set, SPI clock generation ceases and the SPI module enters a power conservation state when the CPU is in wait mode.
  - If SPISWAI is set and the SPI is configured for master, any transmission and reception in progress stops at wait mode entry. The transmission and reception resumes when the SPI exits wait mode.
  - If SPISWAI is set and the SPI is configured as a slave, any transmission and reception in progress continues if the SCK continues to be driven from the master. This keeps the slave synchronized to the master and the SCK.

If the master transmits several bytes while the slave is in wait mode, the slave will continue to send out bytes consistent with the its operation mode at the start of wait mode (i.e. If the slave is currently sending its SPIDR to the master, it will continue to send the same byte. Else if the slave is currently sending the last received byte from the master, it will continue to send each previous master byte).

**NOTE:** *Care must be taken when expecting data from a master while the slave is in wait or stop mode. Even though the shift register will continue to operate, the rest of the SPI is shut down (i.e. a SPIF interrupt will **not** be generated until exiting stop or wait mode). Also, the byte from the shift register will not be copied into the SPIDR register until after the slave SPI has exited wait or stop mode. A SPIF flag and SPIDR copy is only generated if wait mode is entered or exited during a transmission. If the slave enters wait mode in idle mode and exits wait mode in idle mode, neither a SPIF nor a SPIDR copy will occur.*

### 4.8.3 SPI in Stop Mode

Stop mode is dependent on the system. The SPI enters stop mode when the module clock is disabled (held high or low). If the SPI is in master mode and exchanging data when the CPU enters stop mode, the transmission is frozen until the CPU exits stop mode. After stop, data to and from the external SPI is exchanged correctly. In slave mode, the SPI will stay synchronized with the master.

The stop mode is equivalent to the wait mode with the SPISWAI bit set except that the stop mode is dependent on the system and cannot be controlled with the SPISWAI bit.

## Section 5 Reset

### 5.1 General

The reset values of registers and signals are described in the Memory Map and Registers section of the End User Guide (see **Section 3 Memory Map and Registers**) which details the registers and their bit-fields.

- If a data transmission occurs in slave mode after reset without a write to SPIDR, it will transmit garbage, or the byte last received from the master before the reset.
- Reading from the SPIDR after reset will always read a byte of zeros.





## Section 6 Interrupts

The SPI only originates interrupt requests. The following is a description of how the SPI makes a request and how the MCU should acknowledge that request. The interrupt vector offset and interrupt priority are chip dependent.

### 6.1 Interrupt Operation

#### 6.1.1 MODF

MODF occurs when the master detects an error on the  $\overline{SS}$  pin. The master SPI must be configured for the MODF feature (see **Table 3-2 SS Input / Output Selection**). Once MODF is set, the current transfer is halted and the following bit is changed:

- MSTR=0, The master bit in SPICR1 resets.

The MODF interrupt is reflected in the status register MODF flag. Clearing the flag will also clear the interrupt. This interrupt will stay active while the MODF flag is set. MODF has an automatic clearing process which is described in **3.3.4 SPI Status Register**.

#### 6.1.2 SPIF

SPIF occurs when the SPI receives/transmits the last SCK edge in a data transfer operation. Once SPIF is set, it does not clear until it is serviced. SPIF has an automatic clearing process which is described in **3.3.4 SPI Status Register**. In the event that the SPIF is not serviced before the end of the next transfer (i.e. SPIF remains active throughout another transfer), the latter transfers will be ignored and no new data will be copied into the SPIDR.

#### 6.1.3 SPTEF

SPTEF occurs when the SPI Data register transfers a byte into the transmit buffer. Once SPTEF is set, it does not clear until it is serviced. SPTEF has an automatic clearing process which is described in **3.3.4 SPI Status Register**.



# User Guide End Sheet

**Freescale Semiconductor, Inc.**

**FINAL PAGE OF  
36  
PAGES**